

D8254

Programmable Interval Timer

v. 1.08

OVERVIEW

The D8254 is a programmable interval timer/counter, binary compatible with 82C54 industry standard. The D8254 solves one of the most common problems in any microcomputer system, the generation of accurate time delays under software control. The D8254 can be used as a:

- Real time clock
- Even counter
- Digital one-shot
- Programmable rate generator
- Square wave generator
- Binary rate multiplier
- Complex waveform generator
- Complex motor controller

KEY FEATURES

- Three independent 16-bit counters
- Six programmable Counter modes
 - *Interrupt on terminal count*
 - *Hardware retriggerable One-Shot*
 - *Rate Generator*
 - *Square wave mode*
 - *Software triggered strobe*
 - *Hardware triggered strobe*
- Binary or BCD counting
- Status Read Back Command
- Simple interface allows easy connection to microcontrollers
- Fully synthesizable, static design with no internal tri-states

DELIVERABLES

- ◆ Source code:
 - VHDL Source Code or/and
 - VERILOG Source Code or/and
 - Encrypted, or plain text EDIF netlist
- ◆ VHDL & VERILOG test bench environment
 - Active-HDL automatic simulation macros
 - ModelSim automatic simulation macros
 - Tests with reference responses
- ◆ Technical documentation
 - Installation notes
 - HDL core specification
 - Datasheet
- ◆ Synthesis scripts
- ◆ Example application
- ◆ Technical support
 - IP Core implementation support
 - 3 months maintenance
 - Delivery the IP Core updates, minor and major versions changes
 - Delivery the documentation updates
 - Phone & email support

LICENSING

Comprehensible and clearly defined licensing methods, without royalty-per-chip fees, make using of IP Core easy and simple.

Single Site license option – it is dedicated for small and middle sized companies, running their business at one location.

Multi Sites license option – it is dedicated for corporate customers, running their business at several places. Licensed product can be used in selected company branches.

In all cases, number of IP Core instantiation within a project and number of manufactured chips are unlimited. The license is royalty-per-chip free. There is no restrictions regarding the time of use.

There are two formats of delivered IP Core

- VHDL, Verilog RTL synthesizable source code called HDL Source
- FPGA EDIF/NGO/NGD/QXP/VQM, called Netlist

SYMBOL

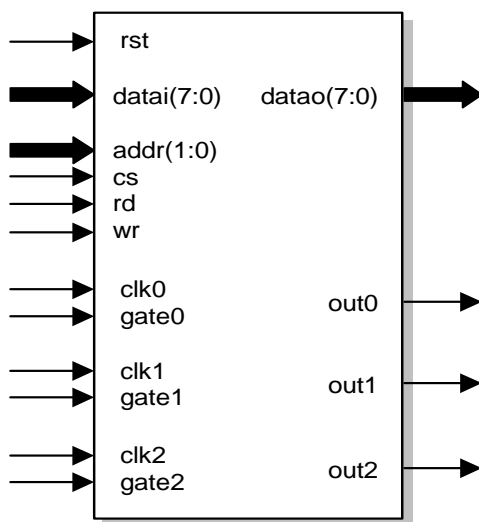

PINS DESCRIPTION

PIN	TYPE	DESCRIPTION
rst	input	Global reset
datai(7:0)	input	Processor data bus (input)
addr(1:0)	input	Processor address lines
cs	input	Chip select
rd	input	Processor read strobe
wr	input	Processor write strobe
clk0	input	Clock input for Counter 0
gate0	input	Gate input for Counter 0
clk1	input	Clock input for Counter 1
gate1	input	Gate input for Counter 1
clk2	input	Clock input for Counter 2
gate2	input	Gate input for Counter 2

datao(7:0)	output	Processor data bus (output)
out0	output	Output of Counter 0
out1	output	Output of Counter 1
out2	output	Output of Counter 2

BLOCK DIAGRAM

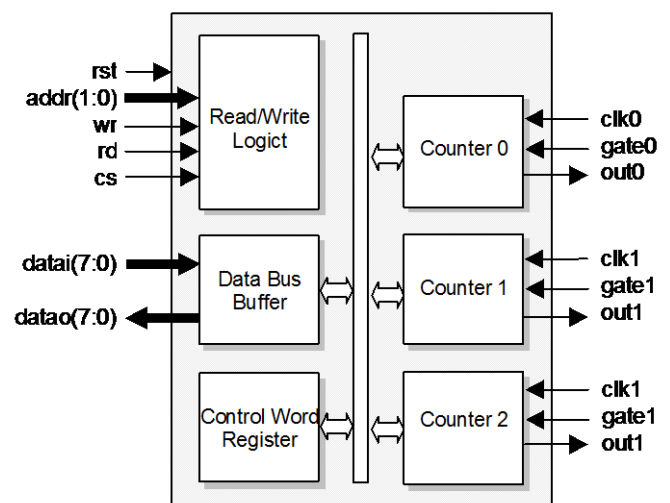

Read Write Logic - The Read/Write Logic accepts inputs from the system bus and generates control signals, for the other functional blocks of the D8254. ADDR(1:0) select one of the three counters or the Control Word Register, to be read from/written into. A "low" on the RD input tells the D8254, that the CPU is reading one of the counters. A "low" on the WR input tells the D8254 that the CPU is writing either a Control Word or an initial count. Both RD and WR are qualified by CS; RD and WR are ignored, unless the 82C54 has been selected by holding CS low. The WR and CLK signals should be synchronous. This is accomplished by using a CLK input signal to the D8254 counters, which is a derivative of the system clock source. Another technique is, to externally synchronize the WR and CLK input signals. This is done by gating WR with CLK.

Data Bus Buffer 8-bit buffer is used to interface the D8254 to the system bus.

Control Word - The Control Word Register is selected by the Read/Write Logic when ADDR(1:0) = 11. If the CPU does a write operation to the D8254, the data is stored in the Control



CONTACT

For any modification or special request, please contact Digital Core Design or local distributors.

Headquarters:

Wroclawska 94

41-902 Bytom, POLAND

e-mail: : info@dcd.pl

tel. : +48 32 282 82 66

fax : +48 32 282 74 37

Distributors:

Please check: <http://dcd.pl/sales/>