

DP8051

Pipelined High Performance

8-bit Microcontroller

v. 5.02

OVERVIEW

The DP8051 is an **ultra high performance, speed optimized** soft core, of a single-chip 8-bit embedded controller, dedicated to operate with **fast** (typically on-chip) and **slow** (off-chip) **memories**. The core has been designed with a special concern for **performance to power consumption** ratio. This ratio is extended by an advanced power management unit **PMU**. DP8051 soft core is 100% binary-compatible with the 8051 industry standard 8-bit microcontroller. There are two configurations of the DP8051: **Harvard**, where internal data and program buses are separated and **von Neumann**, with common program and external data bus. DP8051 has Pipelined RISC architecture and it executes **120-300 million instructions** per second. Dhrystone 2.1 benchmark program runs from **11.46 to 15.55** times faster than the original 80C51 at the same frequency. This performance can also be exploited to great advantage in **low power** applications, where the core can be clocked over ten times slower, than the original implementation, for no performance penalty. DP8051 is delivered with **fully automated testbench** and **complete set of tests**, allowing easy package validation at each stage of SoC design flow.

CPU FEATURES

- 100% software compatible with 8051 industry standard
- Pipelined RISC architecture enables to execute **15.55** times faster than the original 80C51 at the same frequency
- Up to 14.632 VAX MIPS at 100 MHz
- 24 times faster multiplication

- 12 times faster addition
- Up to 256 bytes of internal (on-chip) Data Memory
- Up to 64K bytes of internal (on-chip) or external (off-chip) Program Memory
- Up to 16M bytes of external (off-chip) Data Memory
- User programmable Program Memory Wait States solution, for wide range of memories speed
- User programmable External Data Memory Wait States solution, for wide range of memories speed
- De-multiplexed Address/Data bus to allow easy connection to memory
- Dedicated signal for Program Memory writes.
- Interface for additional Special Function Registers
- Fully synthesizable, static synchronous design, with positive edge clocking and no internal tri-states
- Scan test ready

PERFORMANCE

The following tables give a survey about the Core area and performance in Programmable Logic Devices, after Place & Route (CPU features and peripherals have been included):

Device	Speed grade	Area	F _{max}
FLEX10KE	-1	2250 LC	57 MHz
ACEX1K	-1	2250 LC	57 MHz
APEX20K	-1	2250 LC	50 MHz
APEX20KE	-1	2250 LC	66 MHz
APEX20KC	-7	2250 LC	78 MHz
APEX-II	-7	2250 LC	76 MHz
CYCLONE	-6	2250 LC	91 MHz
CYCLONE-II	-6	2250 LC	93 MHz
CYCLONE-III	-6	2400 LC	111 MHz
Arria GX	-6	1595 ALUT	112 MHz
STRATIX	-5	2250 LC	90 MHz

STRATIX-II	-3	1580 ALUT	160 MHz
STRATIX-III	-2	1580 ALUT	191 MHz
STRATIX-IV	-2	1580 ALUT	196 MHz

Core performance in ALTERA® devices – results given for working system with connected IDATA, CODE and XDATA memories

For the user, the most important feature is the application speed improvement. The most commonly used arithmetic functions and their improvement, are shown in table below. Improvement was computed as {80C51 clock periods}, divided by {DP8051 clock periods} required to execute an identical function. More details are available in the core documentation.

Function	Improvement
8-bit addition (immediate data)	9,00
8-bit addition (direct addressing)	9,00
8-bit addition (indirect addressing)	9,00
8-bit addition (register addressing)	12,00
8-bit subtraction (immediate data)	9,00
8-bit subtraction (direct addressing)	9,00
8-bit subtraction (indirect addressing)	9,00
8-bit subtraction (register addressing)	12,00
8-bit multiplication	16,00
8-bit division	9,60
16-bit addition	12,00
16-bit subtraction	12,00
16-bit multiplication	13,60
32-bit addition	12,00
32-bit subtraction	12,00
32-bit multiplication	12,60
Average speed improvement:	11,12

Dhrystone Benchmark Version 2.1 was used to measure Core performance. The following table provides information about the DP8051 performance, in terms of VAX MIPS per 1 MHz rating.

Device	DMIPS/MHz	Ratio
80C51	0,00941	1,00
DP8051	0,10787	11,46
DP8051+DPTRs	0,13722	14,58
DP8051+DPTRs+SXDM	0,14457	15,36
DP8051+DPTRs+SXDM+MDU32	0,14632	15,55

Core performance in terms of DMIPS per MHz

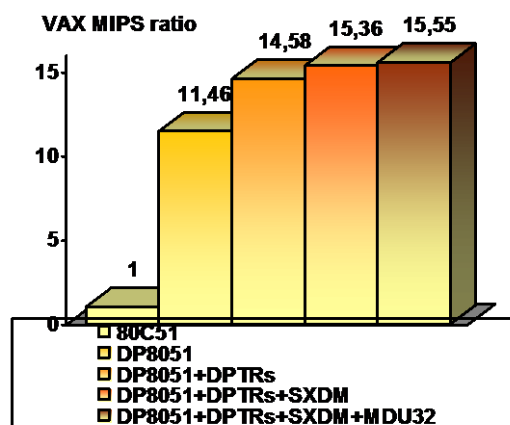

PERIPHERALS

- DoCD™ debug unit
 - Processor execution control
 - Run, Halt
 - Step into instruction
 - Skip instruction
 - Read-write all processor contents
 - Program Counter (PC)
 - Program Memory
 - Internal (direct) Data Memory
 - Special Function Registers (SFRs)
 - External Data Memory
 - Code execution breakpoints
 - two real-time PC breakpoint
 - unlimited number of real-time OPCODE breakpoints
 - Hardware execution watch-points at
 - Internal (direct) Data Memory
 - Special Function Registers (SFRs)
 - External Data Memory
 - Hardware watch-points activated at a certain
 - address by any write into memory
 - address by any read from memory
 - address by write into memory a required data
 - address by read from memory a required data
 - Automatic adjustment of debug data transfer speed rate between HAD and Silicon
 - JTAG Communication interface
- Power Management Unit
 - Power management mode
 - Switchback feature
 - Stop mode
- Interrupt Controller
 - 2 priority levels
 - 2 external interrupt sources
 - 3 interrupt sources from peripherals
- Four 8-bit I/O Ports
 - Bit addressable data direction for each line
 - Read/write of single line and 8-bit group
- Two 16-bit timer/counters
 - Timers clocked by internal source
 - Auto reload 8-bit timers
 - Externally gated event counters
- Full-duplex serial port

- Synchronous mode, fixed baud rate
- 8-bit asynchronous mode, fixed baud rate
- 9-bit asynchronous mode, fixed baud rate
- 9-bit asynchronous mode, variable baud rate

CONFIGURATION

The following parameters of the DP8051 core can be easily adjusted to requirements of dedicated application and technology. Configuration of the core can be effortlessly done, by changing appropriate constants in the package file. There is no need to change any parts of the code.

- Internal Program Memory type
 - synchronous
 - asynchronous
- Internal Program ROM Memory size
 - 0 - 64kB
- Internal Program RAM Memory size
 - 0 - 64kB
- Internal Program Memory fixed size
 - true
 - false
- Interrupts
 - subroutines
 - location
- Power Management Mode
 - used
 - unused
- Stop mode
 - used
 - unused
- DoCD™ debug unit
 - used
 - unused

Besides parameters mentioned above, all available peripherals and external interrupts can be excluded from the core, by changing appropriate constants in the package file.

DELIVERABLES

- ◆ Source code:
 - VHDL Source Code or/and
 - VERILOG Source Code or/and
 - FPGA netlist
- ◆ VHDL & VERILOG test bench environment
 - NCSim automatic simulation macros
 - ModelSim automatic simulation macros
 - Active-HDL automatic simulation macros
 - Tests with reference responses
- ◆ Technical documentation
 - Installation notes

- HDL core specification
- Datasheet
- ◆ Synthesis scripts
- ◆ Example application
- ◆ Technical support
 - IP Core implementation support
 - 3 months maintenance
 - Delivery the IP Core updates, minor and major versions changes
 - Delivery the documentation updates
 - Phone & email support

LICENSING

Comprehensible and clearly defined licensing methods, without royalty-per-chip fees, make using of IP Core easy and simple.

Single Site license option – it is dedicated for small and middle sized companies, running their business at one location.

Multi Sites license option – it is dedicated for corporate customers, running their business at several places. Licensed product can be used in selected company branches. In all cases, number of IP Core instantiation within a project and number of manufactured chips are unlimited. The license is royalty-per-chip free. There is no restrictions regarding the time of use.

There are two formats of delivered IP Core

- VHDL, Verilog RTL synthesizable source code called HDL Source
- FPGA EDIF/NGO/NGD/QXP/VQM called Netlist

DESIGN FEATURES

◆ PROGRAM MEMORY:

The DP8051 soft core is dedicated to operate with Internal and External Program Memory. Internal Program Memory can be implemented as:

- ROM located in address range between $0x0000 \div (ROM_{size}-1)$
- RAM located in address range between $(RAM_{size}-1) \div 0xFFFF$

External Program Memory can be implemented as ROM or RAM located in address range between $ROM_{size} \div RAM_{size}$.

- ◆ **INTERNAL DATA MEMORY:**
The DP8051 can address Internal Data Memory of up to 256 bytes The Internal Data Memory can be implemented as Single-Port synchronous RAM.
- ◆ **EXTERNAL DATA MEMORY:**
The DP8051 soft core can address up to 16 MB of External Data Memory. Extra DPX (*Data Pointer eXtended*) register is used for segments swapping.
- ◆ **USER SPECIAL FUNCTION REGISTERS:**
Up to 104 External (user) Special Function Registers (ESFRs) may be added to the DP8051 design. ESFRs are memory mapped into Direct Memory between addresses 0x80 and 0xFF in the same manner, as core SFRs and may occupy any address, that is not occupied by a SFR core.
- ◆ **WAIT STATES SUPPORT:**
The DP8051 soft core is dedicated for operation with wide range of Program and Data memories. Slow Program and External Data memory may assert a memory WAIT signal to hold up CPU activity, for required period of time.

PINS DESCRIPTION

PIN	TYPE	DESCRIPTION
clk	input	Global clock
reset	input	Global reset input
port0i	input	Port 0 input
port1i	input	Port 1 input
port2i	input	Port 2 input
port3i	input	Port 3 input
ipgramsize	input	Size of on-chip RAM CODE
ipgromsize	input	Size of on-chip ROM CODE
prgramdata	input	Data bus from int. RAM prog. memory
prgromdata	input	Data bus from int. ROM prog. memory
sxdmdatai	input	Data bus from sync external data memory (SXDM)
xdatai	input	Data bus from external memories
ready	input	External memory data ready
ramdatai	input	Data bus from internal data memory
sfrdatai	input	Data bus from user SFR's
int0	input	External interrupt 0
int1	input	External interrupt 1

PIN	TYPE	DESCRIPTION
t0	input	Timer 0 input
t1	input	Timer 1 input
gate0	input	Timer 0 gate input
gate1	input	Timer 1 gate input
rxdi0	input	Serial receiver input 0
tdi	input	DoCD™ TAP data input
tck	input	DoCD™ TAP clock input
tms	input	DoCD™ TAP mode select input
rsto	output	Reset output
port0o	output	Port 0 output
port1o	output	Port 1 output
port2o	output	Port 2 output
port3o	output	Port 3 output
prgaddr	output	Internal program memory address bus
prgdatao	output	Data bus for internal program memory
prgramwr	output	Internal program memory write
sxdmaddr	output	Sync XDATA memory address bus (SXDM)
sxdmdatao	output	Data bus for Sync XDATA memory (SXDM)
sxdmoe	output	Sync XDATA memory read (SXDM)
sxdmwe	output	Sync XDATA memory write (SXDM)
xaddr	output	Address bus for external memories
xdatao	output	Data bus for external memories
xdataz	output	Turn xdata bus into 'Z' state
xprgrd	output	External program memory read
xprgwr	output	External program memory write
xdatard	output	External data memory read
xdatawr	output	External data memory write
ramaddr	output	Internal Data Memory address bus
ramdatao	output	Data bus for internal data memory
ramoe	output	Internal data memory output enable
ramwe	output	Internal data memory write enable
sfraddr	output	Address bus for user SFR's
sfrdatao	output	Data bus for user SFR's
sfroe	output	User SFR's read enable
sfrwe	output	User SFR's write enable
tdo	output	DoCD™ TAP data output
rtck	output	DoCD™ return clock line
debugacs	output	DoCD™ accessing data
coderrun	output	CPU is executing an instruction
pmm	output	Power management mode indicator
stop	output	Stop mode indicator
rxdo0	output	Serial receiver output 0
txdo0	output	Serial transmitter output 0

SYMBOL

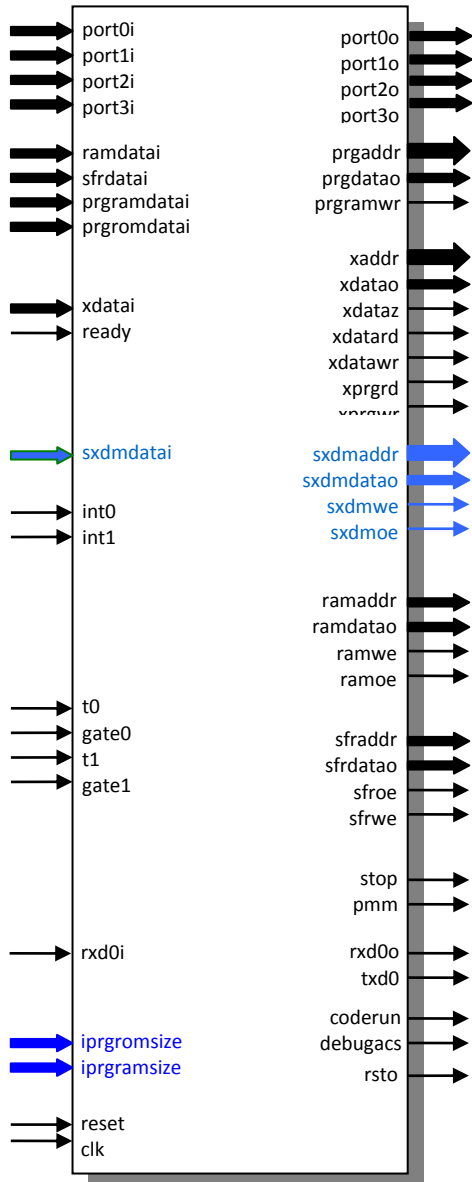

UNITS SUMMARY

ALU – Arithmetic Logic Unit - performs the arithmetic and logic operations, during execution of an instruction. It contains accumulator (ACC), Program Status Word (PSW), (B) registers and related logic, like arithmetic unit, logic unit, multiplier and divider.

Opcode Decoder – Performs an opcode decoding instruction and control functions for all other blocks.

BLOCK DIAGRAM

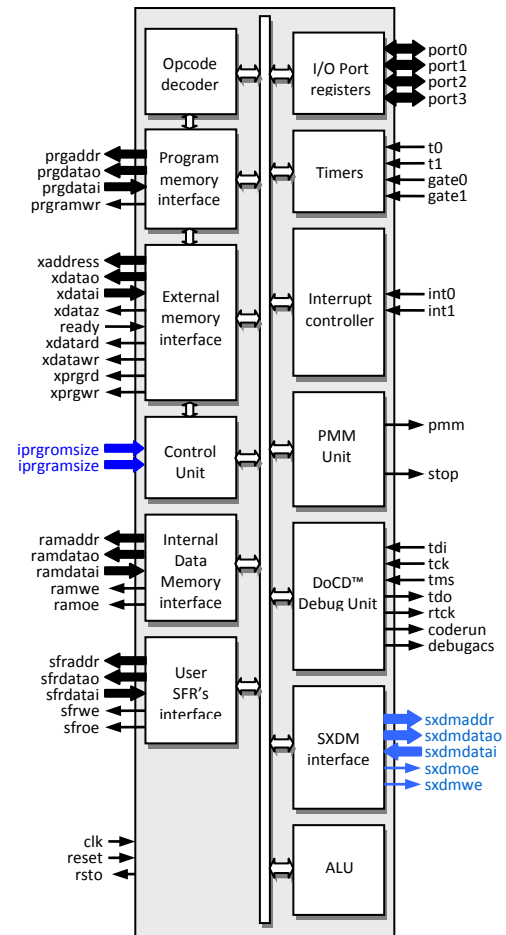

Control Unit – It performs the core synchronization and data flow control. This module is directly connected to Opcode Decoder and it manages execution of all microcontroller tasks.

Program Memory Interface – Program Memory Interface contains Program Counter (PC) and related logic. It performs the instructions code fetching. Program Memory can be also written. This feature allows usage of a small boot loader, to load new program into ROM, RAM, EPROM or FLASH EEPROM storage via UART, SPI, I2C or DoCD™ module.

External Memory Interface - Contains memory access related registers, such as Data Page High (DPH), Data Page Low (DPL) and Data Page Pointer (DPP) registers. It performs the external Program and Data Memory addressing and data transfers. Program fetch cycle length can be programmed by the user. This feature is called Program Memory



Wait States and it allows core, to work with different speed program memories.

Synchronous eXternal Data Memory (SXDM) Interface – contains XDATA memory access related logic, allowing fast access to synchronous memory devices. It performs the external Data Memory addressing and data transfers. This memory can be used to store large variables, frequently accessed by CPU, improving overall performance of application.

Internal Data Memory Interface – Interface controls access into the internal memory of size up to 256 bytes. It contains 8-bit Stack Pointer (SP) register and related logic.

User SFRs Interface – Special Function Registers interface controls access to the special registers. It contains standard and used defined registers and related logic. User defined external devices can be quickly accessed (read, written, modified), by using all direct addressing mode instructions.

Interrupt Controller – Interrupt Controller module is responsible for the interrupt manage system of the external and internal interrupt sources. It contains interrupt related registers, such as Interrupt Enable (IE), Interrupt Priority (IP) and (TCON) registers.

Timers – System timers module. Contains two 16 bits configurable timers: Timer 0 (TH0, TL0), Timer 1 (TH1, TL1) and Timers Mode (TMOD) registers. In the timer mode, timer registers are incremented every 12 (or 4) CLK periods, when appropriate timer is enabled. In the counter mode, the timer registers are incremented every falling transition on their corresponding input pins (T0, T1), if gates are opened (GATE0, GATE1). T0, T1 input pins are sampled every CLK period. It can be used as clock source for UARTs.

UART0 – Universal Asynchronous Receiver and Transmitter module is full duplex, which means, it can transmit and receive concurrently. Includes Serial Configuration register (SCON), serial receiver and transmitter buffer (SBUF) registers. Its receiver is double-buffered, meaning, it can commence reception of a second byte, before the previously received byte has been read from the receive register. Writing to SBUF0 loads the transmit

register and reading SBUF0, reads a physically separate receive register. Works in 3 asynchronous and 1 synchronous modes. UART0 can be synchronized by Timer 1 or Timer 2 (if present in the system).

Ports - Block contains 8051's general purpose I/O ports. Each of port's pin can be read/write as a single bit or as a 8-bit bus P0, P1, P2, P3.

Power Management Unit – Power Management Unit contains advanced power saving mechanisms with switchback feature, allowing external clock control logic to stop clocking (Stop mode) or run core in lower clock frequency (Power Management Mode), to significantly reduce power consumption. Switchback feature allows UARTs and interrupts to be processed in full speed mode, if enabled. It is highly desirable, when microcontroller is planned to be used in portable and power critical applications.

DoCD™ Debug Unit – it's a **real-time hardware debugger**, which provides debugging capability of a whole SoC system. Unlike other on-chip debuggers, **DoCD™** ensures **non-intrusive debugging** of running application. It can halt, run, step into or skip an instruction, read/write any contents of microcontroller, including all registers, internal and external program memories and all SFRs, including user defined peripherals. Hardware breakpoints can be set and controlled on program memory, internal and external data memories, as well as on SFRs. Hardware watchpoints can be set and controlled on internal and external data memories and also on SFRs. Hardware watchpoints are executed, if any write/read occurs at particular address, with certain data pattern or without pattern. Two additional pins: CODERUN and DEBUGACS, indicate the state of the debugger and CPU. CODERUN is active, when CPU is executing an instruction. DEBUGACS pin is active, when any access is performed by **DoCD™** debugger. The **DoCD™** system includes **JTAG interface** and complete set of tools, to communicate and work with core in real time debugging. It is built, as a scalable unit and some features can be turned off, to save silicon and reduce power consumption. When debugger is not used, it is automatically switched to power save mode. Finally,



when debug option is no longer used, whole debugger is turned off.

PROGRAM CODE SPACE IMPLEMENTATION

The figure below shows an example Program Memory space implementation in systems, with DP8051 Microcontroller core. The On-chip Program Memory located in address space between 0kB and 1kB is typically used for BOOT code, with system initialization functions. This part of the code is typically implemented as ROM. The On-chip Program Memory located in address space between 60kB and 64kB, is typically used for timing critical part of the code e.g. interrupt subroutines, arithmetic functions etc. This part of the code is typically implemented as RAM and can be loaded by the BOOT code, during initialization phase from Off-chip memory or through RS232 interface, from external device. From the two spaces mentioned above, program code is executed without wait-states and can achieve a top performance, up to 200 million instructions per second (many instructions executed in one clock cycle). The Off-chip Program Memory located in address space between 1kB and 60kB, is typically used for main code and constants. This part of the code is usually implemented as ROM, SRAM or FLASH device. Because of relatively long access time, the program code executed from mentioned above devices, must be fetched with additional Wait-States. Number of required Wait-States depends on memory access time and DP8051 clock frequency.

In most cases, the proper number of Wait-States cycles is in range 2 to 5. The READY pin can be also dynamically modulated e.g. by SDRAM controller.

The figure below shows typical Program Memories connections in system with DP8051 Microcontroller core.

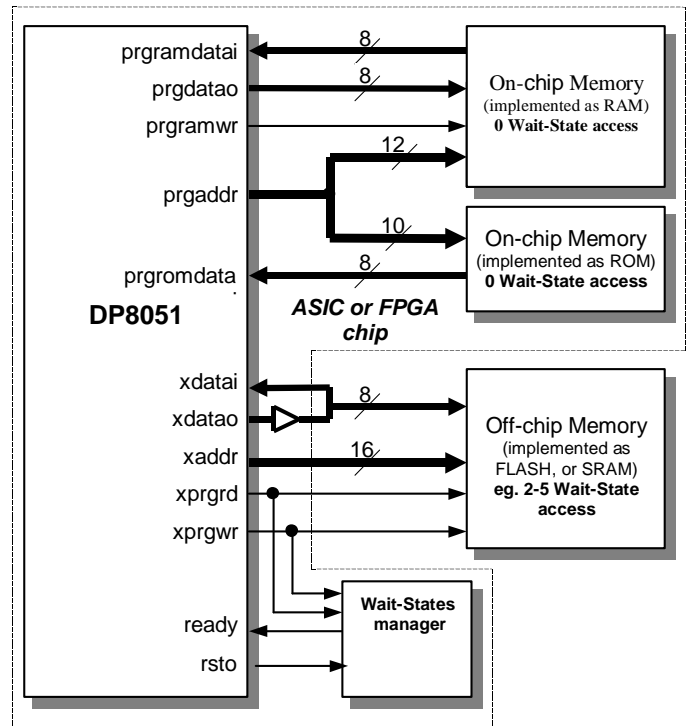

The implementation described above, should be treated as an example. All Program Memory spaces are fully configurable. For timing-critical applications, whole program code can be implemented as on-chip ROM and (or) RAM and executed without Wait-States, but for some other applications, whole program code can be implemented as off-chip ROM or FLASH and executed with required number Wait-State cycles.

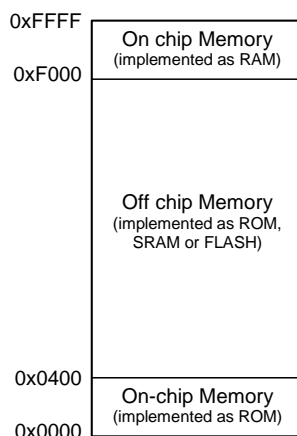

The main features of each DP8051 family member have been summarized in the table below. It gives a brief member characteristic, helping you to select the most suitable IP Core for your application. You can specify your own peripheral set (including listed below and others) and requests the core modifications.

Design	Architecture speed grade	Program Memory space			Stack space size	Internal Data Memory space	External Data Memory space	External Data / Program Memory Wait States	Power Management Unit	Interface for additional SFRs	Interrupt sources	Interrupt levels	Data Pointers	Timer/Counters	UART	I/O Ports	Compare/Capture	Watchdog	Master I ² C Bus Controller	Slave I ² C Bus Controller	SPI	Fixed Point Coprocessor	Floating Point Coprocessor
		on-chip RAM	on-chip ROM	off-chip																			
DP8051CPU	15.6	64k	64k	64k	256	256	16M	✓	✓	✓	2	2	1	-	-	-	-	-	-	-	-	-	-
DP8051	15.6	64k	64k	64k	256	256	16M	✓	✓	✓	5	2	1	2	1	4	-	-	-	-	-	-	-
DP8051X2P	15.6	64k	64k	64k	256	256	16M	✓	✓	✓	15	2	2	3	2	4	✓	✓	✓	✓	✓	✓	✓

DP8051 family of Pipelined High Performance Microcontroller Cores

The main features of each DP80390 family member have been summarized in the table below. It gives a brief member characteristic, helping you to select the most suitable IP Core for your application. You can specify your own peripheral set (including listed below and others) and requests the core modifications.

Design	Architecture speed grade	Program Memory space			Stack space size	Internal Data Memory space	External Data Memory space	External Data / Program Memory Wait States	Power Management Unit	Interface for additional SFRs	Interrupt sources	Interrupt levels	Data Pointers	Timer/Counters	UART	I/O Ports	Compare/Capture	Watchdog	Master I ² C Bus Controller	Slave I ² C Bus Controller	SPI	Fixed Point Coprocessor	Floating Point Coprocessor
		on-chip RAM	on-chip ROM	off-chip																			
DP80390CPU	15.6	64k	64k	8M	256	256	16M	✓	✓	✓	2	2	1	-	-	-	-	-	-	-	-	-	-
DP80390	15.6	64k	64k	8M	256	256	16M	✓	✓	✓	5	2	1	2	1	4	-	-	-	-	-	-	-
DP80390XP	15.6	64k	64k	8M	256	256	16M	✓	✓	✓	15	2	2	3	2	4	✓	✓	✓	✓	✓	✓	✓

DP80390 family of Pipelined High Performance Microcontroller Cores

CONTACT

For any modification or special request, please contact Digital Core Design or local distributors.

Headquarters:

Wroclawska 94

41-902 Bytom, POLAND

e-mail: : info@dcd.pl

tel. : +48 32 282 82 66

fax : +48 32 282 74 37

Distributors:

Please check: <http://dcd.pl/sales/>