

## DSPI Core connection to SPI Bus

This document describes how to connect DSPI Core into global SPI Bus.

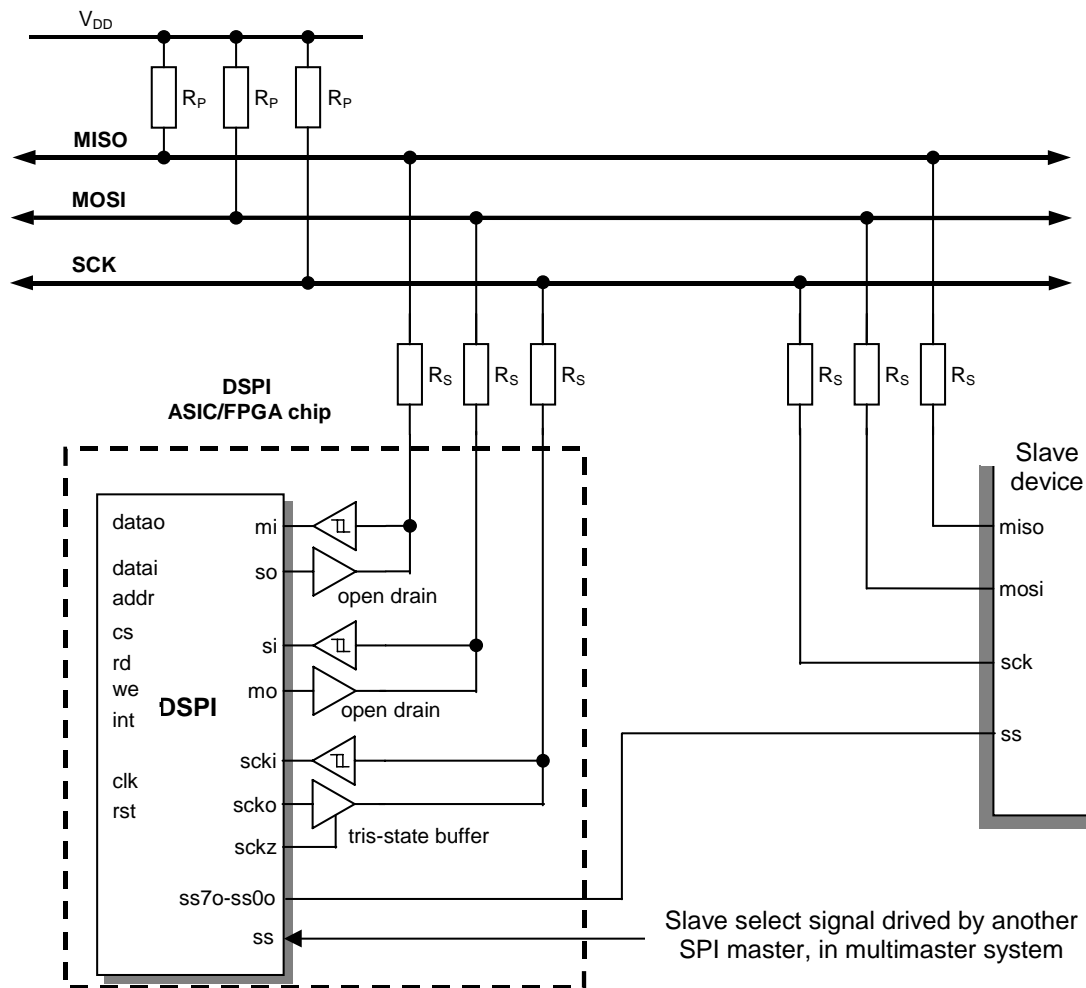

Connection DSPI to global SPI bus

Input Schmidt gates are recommended especially in systems with fast data transfer (>3Mb per second). They prevent incidental erroneous behavior caused by slow rising edges on input MI, SI and SCKI lines. The tri-state buffer on SCKO pin, should be implemented only in multimaster systems, it prevents driving SCK line by two different SPI Master devices. When the DSPI device is configured as an SPI Slave, the SCKO line is driven in to high impedance.