

# DP8051CPU

## Pipelined High Performance 8-bit Microcontroller ver 5.02

### OVERVIEW

DP8051CPU is an **ultra high performance, speed optimized** soft core of a single-chip 8-bit embedded controller dedicated for operation with **fast** (typically on-chip) and **slow** (off-chip) **memories**. The core has been designed with a special concern about **performance to power consumption** ratio. This ratio is extended by an advanced power management unit **PMU**.

DP8051CPU soft core is 100% binary-compatible with the industry standard 8051 8-bit microcontroller. There are two configurations of DP8051CPU: **Harward** where internal data and program buses are separated and **von Neumann** with common program and external data bus. DP8051CPU has Pipelined RISC architecture **and** executes **120-300 million instructions** per second. [Dhrystone 2.1 benchmark program runs from 11.46 to 15.55 times faster than the original 80C51 at the same frequency](#). This performance can also be exploited to great advantage in **low power** applications where the core can be clocked over ten times more slowly than the original implementation for no performance penalty.

DP8051CPU is delivered with **fully automated testbench** and **complete set of tests** allowing easy package validation at each stage of SoC design flow.

### CPU FEATURES

- 100% software compatible with industry standard 8051
- Pipelined RISC architecture enables to execute **15.55** times faster than the original 80C51 at the same frequency
- Up to 14.632 VAX MIPS at 100 MHz
- 24 times faster multiplication
- 12 times faster addition
- Up to 256 bytes of internal (on-chip) Data Memory
- Up to 64K bytes of internal (on-chip) or external (off-chip) Program Memory
- Up to 16M bytes of external (off-chip) Data Memory
- User programmable Program Memory Wait States solution for wide range of memories speed
- User programmable External Data Memory Wait States solution for wide range of memories speed
- De-multiplexed Address/Data bus to allow easy connection to memory
- Dedicated signal for Program Memory writes.
- Interface for additional Special Function Registers
- Fully synthesizable, static synchronous design with positive edge clocking and no internal tri-states
- Scan test ready

## PERFORMANCE

The following tables give a survey about the Core area and performance in Programmable Logic Devices after Place & Route (all CPU features and peripherals have been included):

Device	Speed grade	Area	F <sub>max</sub>
XP	-5	1940 LUT4s	76 MHz
EC	-5	1940 LUT4s	82 MHz
ECP	-5	1940 LUT4s	88 MHz
XP	-7	1880 LUT4s	101 MHz
ECP2	-7	1880 LUT4s	120 MHz
ECP2M	-7	1880 LUT4s	123 MHz
SC	-7	1960 LUT4s	149 MHz

Core performance in LATTICE® devices – results given for working system with connected IDATA, CODE and XDATA memories

For a user the most important is application speed improvement. The most commonly used arithmetic functions and their improvements are shown in table below. An improvement was computed as {80C51 clock periods} divided by {DP8051CPU clock periods} required to execute an identical function. More details are available in core documentation.

Function	Improvement
8-bit addition ( <i>immediate data</i> )	9,00
8-bit addition ( <i>direct addressing</i> )	9,00
8-bit addition ( <i>indirect addressing</i> )	9,00
8-bit addition ( <i>register addressing</i> )	12,00
8-bit subtraction ( <i>immediate data</i> )	9,00
8-bit subtraction ( <i>direct addressing</i> )	9,00
8-bit subtraction ( <i>indirect addressing</i> )	9,00
8-bit subtraction ( <i>register addressing</i> )	12,00
8-bit multiplication	16,00
8-bit division	9,60
16-bit addition	12,00
16-bit subtraction	12,00
16-bit multiplication	13,60
32-bit addition	12,00
32-bit subtraction	12,00
32-bit multiplication	12,60
<b>Average speed improvement:</b>	<b>11,12</b>

Dhrystone Benchmark Version 2.1 was used to measure Core performance. The following table gives a survey about the DP8051 performance in terms of VAX MIPS per 1 MHz rating.

Device	DMIPS/MHz	Ratio
80C51	0,00941	1,00
DP8051	0,10787	11,46
DP8051+DPTRs	0,13722	14,58
DP8051+DPTRs+SXDM	0,14457	15,36
DP8051+DPTRs+SXDM+MDU32	0,14632	15,55

Core performance in terms of DMIPS per MHz

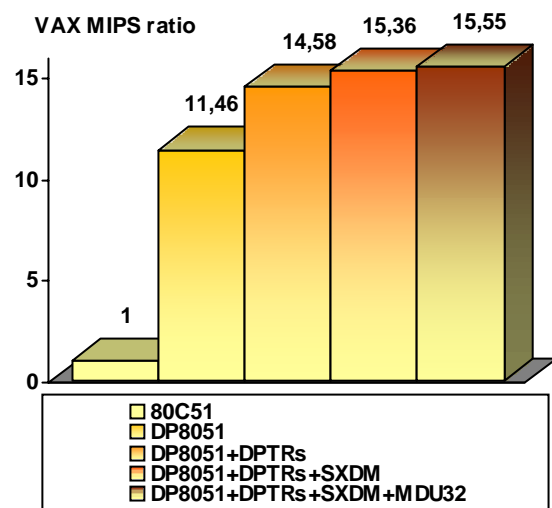

## PERIPHERALS

- DoCD™ debug unit
  - Processor execution control
    - Run, Halt
    - Step into instruction
    - Skip instruction
  - Read-write all processor contents
    - Program Counter (PC)
    - Program Memory
    - Internal (direct) Data Memory
    - Special Function Registers (SFRs)
    - External Data Memory
  - Code execution breakpoints
    - two real-time PC breakpoint
    - unlimited number of real-time OPCODE breakpoints
  - Hardware execution watch-points at
    - Internal (direct) Data Memory
    - Special Function Registers (SFRs)
    - External Data Memory
  - Hardware watch-points activated at a certain
    - address by any write into memory
    - address by any read from memory
    - address by write into memory a required data
    - address by read from memory a required data
  - Automatic adjustment of debug data transfer speed rate between HAD and Silicon
  - JTAG Communication interface
- Power Management Unit
  - Power management mode
  - Switchback feature
  - Stop mode
- Interrupt Controller
  - 2 priority levels
  - 2 external interrupt sources

## CONFIGURATION

The following parameters of the DP8051CPU core can be easily adjusted to requirements of dedicated application and technology. Configuration of the core can be prepared by effortlessly changing appropriate constants in package file. There is no need to change any parts of the code.

- Internal Program Memory
  - synchronous
  - asynchronous
- Internal Program ROM
  - Memory size
  - 0 - 64kB
- Internal Program RAM
  - Memory size
  - 0 - 64kB
- Internal Program Memory
  - fixed size
  - true
  - false
- Interrupts
  - subroutines
  - location
- Power Management Mode
  - used
  - unused
- Stop mode
  - used
  - unused
- DoCD™ debug unit
  - used
  - unused

Besides mentioned above parameters all available peripherals and external interrupts can be excluded from the core by changing appropriate constants in package file.

## DELIVERABLES

- ◆ Source code:
  - VHDL Source Code or/and
  - VERILOG Source Code or/and
  - FPGA netlist
- ◆ VHDL & VERILOG test bench environment
  - Active-HDL automatic simulation macros
  - ModelSim automatic simulation macros
  - NCSim automatic simulation macros
  - Tests with reference responses
- ◆ Technical documentation
  - Installation notes
  - HDL core specification
  - Datasheet
- ◆ Synthesis scripts
- ◆ Example application
- ◆ Technical support
  - IP Core implementation support
  - 3 months maintenance
    - Delivery the IP Core updates, minor and major versions changes
    - Delivery the documentation updates
    - Phone & email support

## LICENSING

Comprehensible and clearly defined licensing methods without royalty per chip fees make using of IP Core easy and simply.

Single Site license option is dedicated for small and middle sized companies making its business in one place.

Multi Sites license option is dedicated for corporate customers making its business in several places. Licensed product can be used in selected branches of corporate.

In all cases number of IP Core instantiations within a project, and number of manufactured chips are unlimited. The license is royalty per chip free. There is no time of use restrictions.

There are two formats of delivered IP Core

- VHDL, Verilog RTL synthesizable source code called HDL Source
- FPGA EDIF/NGO/NGD/QXP/VQM called Netlist

## DESIGN FEATURES

### ◆ PROGRAM MEMORY:

The DP8051CPU soft core is dedicated for operation with Internal and External Program Memory. Internal Program Memory can be implemented as:

- ROM located in address range between  $0x0000 \div (ROM_{size}-1)$
- RAM located in address range between  $(RAM_{size}-1) \div 0xFFFF$

External Program Memory can be implemented as ROM or RAM located in address range between  $ROM_{size} \div RAM_{size}$ .

### ◆ INTERNAL DATA MEMORY:

The DP8051CPU can address Internal Data Memory of up to 256 bytes The Internal Data Memory can be implemented as Single-Port synchronous RAM.

### ◆ EXTERNAL DATA MEMORY:

The DP8051CPU soft core can address up to 16 MB of External Data Memory. Extra DPX (*Data Pointer eXtended*) register is used for segments swapping.

### ◆ USER SPECIAL FUNCTION REGISTERS:

Up to 104 External (user) Special Function Registers (ESFRs) may be added to the DP8051CPU design. ESFRs are memory mapped into Direct Memory between addresses 0x80 and 0xFF in the same manner as core SFRs and may occupy any address that is not occupied by a core SFR.

### ◆ WAIT STATES SUPPORT:

The DP8051CPU soft core is dedicated for operation with wide range of Program and Data memories. Slow Program and External Data memory may assert a memory Wait signal to hold up CPU activity.



### SYMBOL

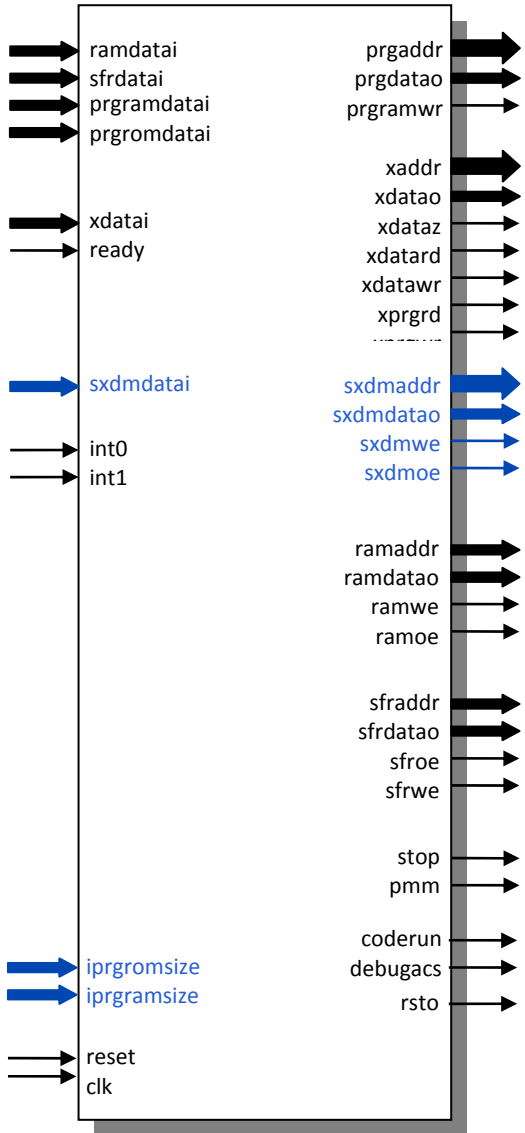

### BLOCK DIAGRAM

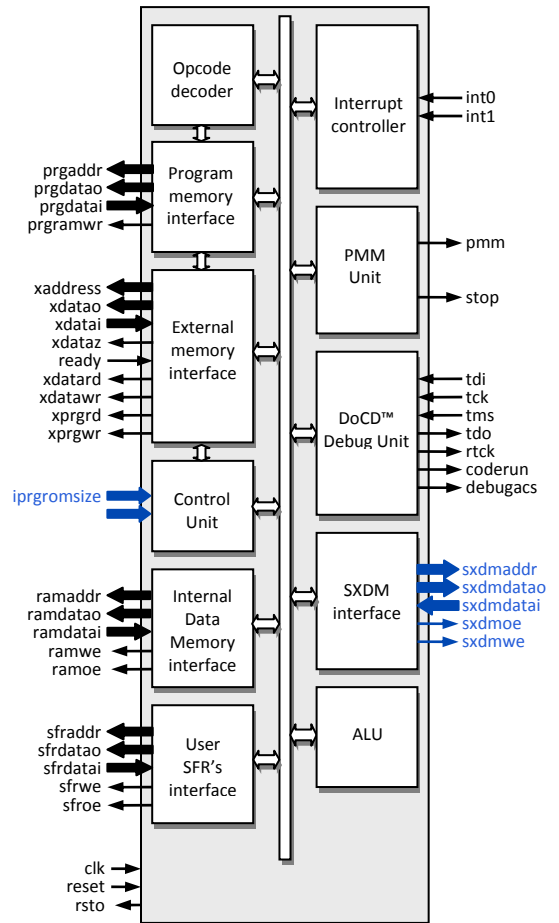

## PINS DESCRIPTION

PIN	TYPE	DESCRIPTION
clk	input	Global clock
reset	input	Global reset
port0i	input	Port 0 input
port1i	input	Port 1 input
port2i	input	Port 2 input
port3i	input	Port 3 input
ipgramsize	input	Size of on-chip RAM CODE
ipgromsize	input	Size of on-chip ROM CODE
prgramdata	input	Data bus from int. RAM prog. memory
prgomdata	input	Data bus from int. ROM prog. memory
sxdmdatai	input	Data bus from sync external data memory (SXDM)
xdatai	input	Data bus from external memories
ready	input	External memory data ready
ramdatai	input	Data bus from internal data memory
sfrdatai	input	Data bus from user SFR's
int0	input	External interrupt 0
int1	input	External interrupt 1
tdi	input	DoCD™ TAP data input
tck	input	DoCD™ TAP clock input
tms	input	DoCD™ TAP mode select input
rsto	output	Reset output
port0o	output	Port 0 output
port1o	output	Port 1 output
port2o	output	Port 2 output
port3o	output	Port 3 output
prgaddr	output	Internal program memory address bus
prgdatao	output	Data bus for internal program memory
prgramwr	output	Internal program memory write
sxdmaddr	output	Sync XDATA memory address bus (SXDM)
sxdmdatao	output	Data bus for Sync XDATA memory (SXDM)
sxdmoe	output	Sync XDATA memory read (SXDM)
sxdmwe	output	Sync XDATA memory write (SXDM)
xaddr	output	Address bus for external memories
xdatao	output	Data bus for external memories
xdataz	output	Turn xdata bus into 'Z' state
xprgrd	output	External program memory read
xprgwr	output	External program memory write
xdatard	output	External data memory read
xdatawr	output	External data memory write

PIN	TYPE	DESCRIPTION
ramaddr	output	Internal Data Memory address bus
ramdatao	output	Data bus for internal data memory
ramoe	output	Internal data memory output enable
ramwe	output	Internal data memory write enable
sfraddr	output	Address bus for user SFR's
sfrdatao	output	Data bus for user SFR's
sfroee	output	User SFR's read enable
sfrwe	output	User SFR's write enable
tdo	output	DoCD™ TAP data output
rtck	output	DoCD™ return clock line
debugacs	output	DoCD™ accessing data
coderun	output	CPU is executing an instruction
pmm	output	Power management mode indicator
stop	output	Stop mode indicator

## UNITS SUMMARY

**ALU** – Arithmetic Logic Unit performs the arithmetic and logic operations during execution of an instruction. It contains accumulator (ACC), Program Status Word (PSW), (B) registers and related logic such as arithmetic unit, logic unit, multiplier and divider.

**Opcode Decoder** – Performs an instruction opcode decoding and the control functions for all other blocks.

**Control Unit** – Performs the core synchronization and data flow control. This module is directly connected to Opcode Decoder and manages execution of all microcontroller tasks.

**Program Memory Interface** – Contains Program Counter (PC) and related logic. It performs the instructions code fetching. Program Memory can be also written. This feature allows usage of a small boot loader loading new program into RAM, EPROM or FLASH EEPROM storage via UART, SPI, I2C or DoCD™ module.

**External Memory Interface** - Contains memory access related registers such as Data Page High (DPH), Data Page Low (DPL) and Data Pointer eXtended (DPX) registers. It performs the external Program and Data Memory addressing and data transfers. Program fetch cycle length can be programmed by user. This feature is called Program Memory Wait States, and allows core to work with different speed program memories.

**Synchronous eXternal Data Memory (SXDM) Interface** – contains XDATA memory access related logic allowing fast access to synchronous memory devices. It performs the external Data Memory addressing and data transfers. This memory can be used to store large variables frequently accessed by CPU, improving overall performance of application.

**Internal Data Memory Interface** – Internal Data Memory interface controls access into the internal 256 bytes memory. It contains 8-bit Stack Pointer (SP) register and related logic.

**User SFRs Interface** – Special Function Registers interface controls access to the special registers. It contains standard and used defined registers and

related logic. User defined external devices can be quickly accessed (read, written, modified) using all direct addressing mode instructions.

**Interrupt Controller** – Interrupt control module is responsible for the interrupt manage system for the external and internal interrupt sources. It contains interrupt related registers such as Interrupt Enable (IE), Interrupt Priority (IP) and (TCON) registers.

**Power Management Unit** – Block contains advanced power saving mechanisms with switchback feature, allowing external clock control logic to stop clocking (Stop mode) or run core in lower clock frequency (Power Management Mode) to significantly reduce power consumption. Switchback feature allows UARTs, and interrupts to be processed in full speed mode if enabled. It is very desired when microcontroller is planned to use in portable and power critical applications.

**DoCD™ Debug Unit** – it's a real-time hardware debugger provides debugging capability of a whole SoC system. In contrast to other on-chip debuggers DoCD™ provides non-intrusive debugging of running application. It can halt, run, step into or skip an instruction, read/write any contents of microcontroller including all registers, internal, external, program memories, all SFRs including user defined peripherals. Hardware breakpoints can be set and controlled on program memory, internal and external data memories, as well as on SFRs. Hardware breakpoint is executed if any write/read occurred at particular address with certain data pattern or without pattern. Two additional pins CODERUN, DEBUGACS indicate the state of the debugger and CPU. CODERUN is active when CPU is executing an instruction. DEBUGACS pin is active when any access is performed by DoCD™ debugger. The DoCD™ system includes **JTAG interface** and complete set of tools to communicate and work with core in real time debugging. It is built as scalable unit and some features can be turned off to save silicon and reduce power consumption. A special care on power consumption has been taken, and when debugger is not used it is automatically switched in power save mode. Finally whole debugger is turned off when debug option is no longer used.

## PROGRAM CODE SPACE IMPLEMENTATION

The figure below shows an example Program Memory space implementation in systems with DP8051CPU Microcontroller core. The On-chip Program Memory located in address space between 0kB and 1kB is typically used for BOOT code with system initialization functions. This part of the code is typically implemented as ROM. The On-chip Program Memory located in address space between 60kB and 64kB is typically used for timing critical part of the code e.g. interrupt subroutines, arithmetic functions etc. This part of the code is typically implemented as RAM and can be loaded by the BOOT code during initialization phase from Off-chip memory or through RS232 interface from external device. From the two mentioned above spaces program code is executed without wait-states and can achieve a top performance up to 200 million instructions per second (many instructions executed in one clock cycle). The Off-chip Program Memory located in address space between 1kB and 60kB is typically used for main code and constants. This part of the code is usually implemented as ROM, SRAM or FLASH device. Because of relatively long access time the program code executed from mentioned above devices must be fetched with additional Wait-States. Number of required Wait-States depends on memory access time and DP8051CPU clock frequency. In most cases the proper number of Wait-States cycles is between 2-5. The READY pin can be also dynamically modulated e.g. by SDRAM controller.

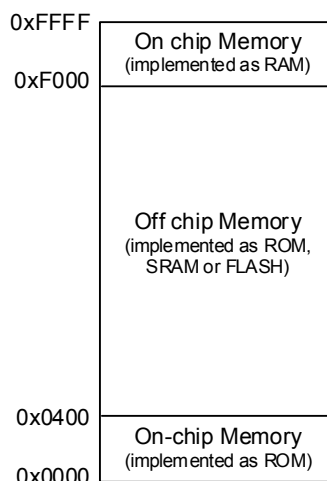

The figure below shows typical Program Memories connections in system with DP8051CPU Microcontroller core.

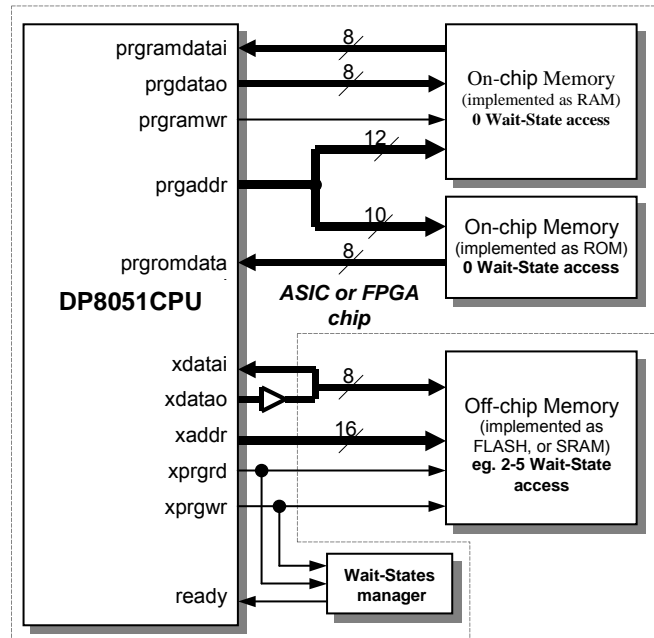

The described above implementation should be treated as an example. All Program Memory spaces are fully configurable. For timing-critical applications whole program code can be implemented as on-chip ROM and (or) RAM and executed without Wait-States, but for some other applications whole program code can be implemented as off-chip ROM or FLASH and executed with required number Wait-State cycles.

The main features of each DP8051 family member have been summarized in table below. It gives a briefly member characterization helping user to select the most suitable IP Core for its application. User can specify its own peripheral set (including listed below and the others) and requests the core modifications.

Design	Architecture speed grade	Program Memory space			Stack space size	Internal Data Memory space	External Data Memory space	External Data / Program Memory Wait States	Power Management Unit	Interface for additional SFRs	Interrupt sources	Interrupt levels	Data Pointers	Timer/Counters	UART	I/O Ports	Compare/Capture	Watchdog	Master I <sup>2</sup> C Bus Controller	Slave I <sup>2</sup> C Bus Controller	SPI	Fixed Point Coprocessor	Floating Point Coprocessor
		on-chip RAM	on-chip ROM	off-chip																			
DP8051CPU	15.6	64k	64k	64k	256	256	16M	✓	✓	✓	2	2	1	-	-	-	-	-	-	-	-	-	-
DP8051	15.6	64k	64k	64k	256	256	16M	✓	✓	✓	5	2	1	2	1	4	-	-	-	-	-	-	-
DP8051XP	15.6	64k	64k	64k	256	256	16M	✓	✓	✓	15	2	2	3	2	4	✓	✓	✓	✓	✓	✓	✓

*DP8051 family of Pipelined High Performance Microcontroller Cores*

The main features of each DP80390 family member have been summarized in table below. It gives a briefly member characterization helping user to select the most suitable IP Core for its application. User can specify its own peripheral set (including listed below and the others) and requests the core modifications.

Design	Architecture speed grade	Program Memory space			Stack space size	Internal Data Memory space	External Data Memory space	External Data / Program Memory Wait States	Power Management Unit	Interface for additional SFRs	Interrupt sources	Interrupt levels	Data Pointers	Timer/Counters	UART	I/O Ports	Compare/Capture	Watchdog	Master I <sup>2</sup> C Bus Controller	Slave I <sup>2</sup> C Bus Controller	SPI	Fixed Point Coprocessor	Floating Point Coprocessor
		on-chip RAM	on-chip ROM	off-chip																			
DP80390CPU	15.6	64k	64k	8M	256	256	16M	✓	✓	✓	2	2	1	-	-	-	-	-	-	-	-	-	-
DP80390	15.6	64k	64k	8M	256	256	16M	✓	✓	✓	5	2	1	2	1	4	-	-	-	-	-	-	-
DP80390XP	15.6	64k	64k	8M	256	256	16M	✓	✓	✓	15	2	2	3	2	4	✓	✓	✓	✓	✓	✓	✓

*DP80390 family of Pipelined High Performance Microcontroller Cores*

## CONTACTS

For any modification or special request contact to DCD.

### **Headquarters:**

Wroclawska 94

41-902 Bytom, POLAND

*e-mail:* [info@dcd.pl](mailto:info@dcd.pl)

*tel.* : +48 32 282 82 66

*fax* : +48 32 282 74 37

### **Distributors:**

Please check <http://www.dcd.pl/apartn.php>