

DP8051XP

Pipelined High Performance 8-bit Microcontroller ver 5.02

OVERVIEW

DP8051XP is a **ultra high performance, speed optimized** soft core of a single-chip 8-bit embedded controller dedicated for operation with **fast** (typically on-chip) and **slow** (off-chip) memories. The core has been designed with a special concern about **performance to power consumption** ratio. This ratio is extended by an advanced power management unit **PMU**.

DP8051XP soft core is 100% binary-compatible with the industry standard 8051 8-bit microcontroller. There are two configurations of DP8051XP: **Harward** where internal data and program buses are separated and **von Neumann** with common program and external data bus. DP8051XP has Pipelined RISC architecture and executes **120-300 million instructions** per second. [Dhrystone 2.1 benchmark program runs from 11.46 to 15.55 times faster than the original 80C51 at the same frequency](#). This performance can also be exploited to great advantage in **low power** applications where the core can be clocked over ten times more slowly than the original implementation for no performance penalty.

DP8051XP is **fully customizable**, which means it is delivered in the exact configuration to meet users' requirements. *There is no need to pay extra for not used features and wasted silicon.* It includes **fully automated testbench** with **complete set of tests** allowing easy package validation at each stage of SoC design flow.

CPU FEATURES

- 100% software compatible with industry standard 8051
- Pipelined RISC architecture enables to execute **15.55** times faster than the original 80C51 at the same frequency
- Up to 14.632 VAX MIPS at 100 MHz
- 24 times faster multiplication
- 12 times faster addition
- 2 Data Pointers (DPTR) for faster memory blocks copying
 - *Advanced INC & DEC modes*
 - *Auto-switch of current DPTR*
- Up to 256 bytes of internal (on-chip) Data Memory
- Up to 64K bytes of internal (on-chip) or external (off-chip) Program Memory
- Up to 16M bytes of external (off-chip) Data Memory
 - *Synchronous eXternal Data Memory (SXDM) Interface*
- User programmable Program Memory Wait States solution for wide range of memories speed
- User programmable External Data Memory Wait States solution for wide range of memories speed
- De-multiplexed Address/Data bus to allow easy connection to memory
- Dedicated signal for Program Memory writes.

- Interface for additional Special Function Registers
- Fully synthesizable, static synchronous design with positive edge clocking and no internal tri-states
- Scan test ready

PERFORMANCE

The following tables give a survey about the Core area and performance in Programmable Logic Devices after Place & Route (CPU features and peripherals have been included):

Device	Speed grade	F _{max}
XP	-5	67 MHz
EC	-5	75 MHz
ECP	-5	79 MHz
XP	-7	91 MHz
ECP2	-7	110 MHz
ECP2M	-7	113 MHz
SC	-7	129 MHz

Core performance in LATTICE® devices– results given for working system with connected IDATA, CODE and XDATA memories

For a user the most important is application speed improvement. The most commonly used arithmetic functions and their improvement are shown in table below. Improvement was computed as {80C51 clock periods} divided by {DP8051XP clock periods} required to execute an identical function. More details are available in core documentation.

Function	Improvement
8-bit addition (<i>immediate data</i>)	9,00
8-bit addition (<i>direct addressing</i>)	9,00
8-bit addition (<i>indirect addressing</i>)	9,00
8-bit addition (<i>register addressing</i>)	12,00
8-bit subtraction (<i>immediate data</i>)	9,00
8-bit subtraction (<i>direct addressing</i>)	9,00
8-bit subtraction (<i>indirect addressing</i>)	9,00
8-bit subtraction (<i>register addressing</i>)	12,00
8-bit multiplication	16,00
8-bit division	9,60
16-bit addition	12,00
16-bit subtraction	12,00
16-bit multiplication	13,60
32-bit addition	12,00
32-bit subtraction	12,00
32-bit multiplication	12,60
Average speed improvement:	11,12

Dhrystone Benchmark Version 2.1 was used to measure Core performance. The following table gives a survey about the DP8051XP performance in terms of VAX MIPS per 1 MHz rating.

Device	DMIPS/MHz	Ratio
80C51	0,00941	1,00
DP8051	0,10787	11,46
DP8051+DPTRs	0,13722	14,58
DP8051+DPTRs+SXDM	0,14457	15,36
DP8051+DPTRs+SXDM+MDU32	0,14632	15,55

Core performance in terms of DMIPS per MHz

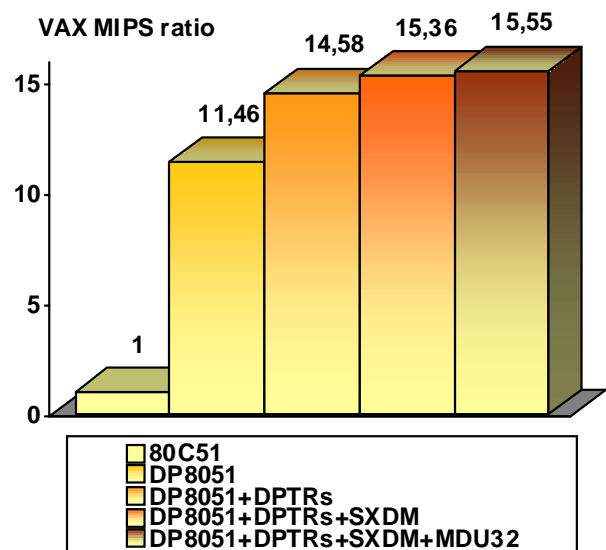

Area utilized by the each unit of DP8051XP core in vendor specific technologies is summarized in table below.

Component	Area [LUT4s]
CPU*	1770
DPTR1 register	50
DPTR0 decrement	40
DPTR1 decrement	40
DPTR0 & DPTR1 auto-switch	30
Timed Access protection	20
Interrupt Controller	170
INT2-INT6	100
Power Management Unit	10
I/O ports	120
Timers	190
Timer 2	190
UART0	260
UART1	260
Master I2C Unit	295
Slave I2C Unit	195
SPI Unit	130
Compare Capture Unit	170
Watchdog Timer	110
Multiply Divide Unit 32	880
DoCD	900
Total area	5930

*CPU – consisted of ALU, Opcode Decoder, Control Unit, Program & Internal & External Memory Interfaces, User SFRs Interface

Core components area utilization in XP/EC/ECP/SC

Component	Area [LUT4s]
CPU*	1684
DPTR1 register	47
DPTR0 decrement	38
DPTR1 decrement	38
DPTR0 & DPTR1 auto-switch	28
Timed Access protection	19
Interrupt Controller	160
INT2-INT6	94
Power Management Unit	9
I/O ports	113
Timers	179
Timer 2	179
UART0	247
UART1	247
Master I2C Unit	280
Slave I2C Unit	186
SPI Unit	122
Compare Capture Unit	160
Watchdog Timer	103
Multiply Divide Unit 32	830
Total area	4763

*CPU – consisted of ALU, Opcode Decoder, Control Unit, Program & Internal & External Memory Interfaces, User SFRs Interface

Core components area utilization in XP/EC2/ECP2/ECP2M

PERIPHERALS

- DoCD™ debug unit
 - Processor execution control
 - Run, Halt
 - Step into instruction
 - Skip instruction
 - Read-write all processor contents
 - Program Counter (PC)
 - Program Memory
 - Internal (direct) Data Memory
 - Special Function Registers (SFRs)
 - External Data Memory
 - Code execution breakpoints
 - two real-time PC breakpoint
 - unlimited number of real-time OPCODE breakpoints
 - Hardware execution watch-points at
 - Internal (direct) Data Memory
 - Special Function Registers (SFRs)
 - External Data Memory
 - Hardware watch-points activated at a certain
 - address by any write into memory
 - address by any read from memory
 - address by write into memory a required data
 - address by read from memory a required data
 - Automatic adjustment of debug data transfer speed rate between HAD and Silicon
 - JTAG Communication interface
- Power Management Unit
 - Power management mode
 - Switchback feature
 - Stop mode
- Extended Interrupt Controller
 - 2 priority levels
 - Up to 7 external interrupt sources
 - Up to 8 interrupt sources from peripherals
- Four 8-bit I/O Ports
 - Bit addressable data direction for each line
 - Read/write of single line and 8-bit group
- Three 16-bit timer/counters
 - Timers clocked by internal source
 - Auto reload 8/16-bit timers
 - Externally gated event counters

- Two full-duplex serial ports
 - Synchronous mode, fixed baud rate
 - 8-bit asynchronous mode, fixed baud rate
 - 9-bit asynchronous mode, fixed baud rate
 - 9-bit asynchronous mode, variable baud rate
- I2C bus controller - Master
 - 7-bit and 10-bit addressing modes
 - NORMAL, FAST, HIGH speeds
 - Multi-master systems supported
 - Clock arbitration and synchronization
 - User defined timings on I2C lines
 - Wide range of system clock frequencies
 - Interrupt generation
- I2C bus controller - Slave
 - NORMAL speed 100 kbs
 - FAST speed 400 kbs
 - HIGH speed 3400 kbs
 - Wide range of system clock frequencies
 - User defined data setup time on I2C lines
 - Interrupt generation
- SPI – Master and Slave Serial Peripheral Interface
 - Supports speeds up to ¼ of system clock
 - Mode fault error
 - Write collision error
 - Four transfer formats supported
 - System errors detection
 - Allows operation from a wide range of system clock frequencies (build-in 5-bit timer)
 - Interrupt generation
- Programmable Watchdog Timer
- 16-bit Compare/Capture Unit
 - Events capturing
 - Pulses generation
 - Digital signals generation
 - Gated timers
 - Sophisticated comparator
 - Pulse width modulation
 - Pulse width measuring
- Fixed-Point arithmetic coprocessor
 - Multiplication - 16bit * 16bit
 - Multiplication - 32bit * 32bit
 - Division - 32bit / 32bit
 - Division - 16bit / 16bit
- Floating-Point arithmetic coprocessor IEEE-754 standard single precision
 - FADD, FSUB - addition, subtraction
 - FMUL, FDIV- multiplication, division
 - FSQRT- square root
 - FUCOM - compare
 - FCHS - change sign
 - FABS - absolute value
- Floating-Point math coprocessor - IEEE-754 standard single precision real, word and short integers
 - FADD, FSUB- addition, subtraction
 - FMUL, FDIV- multiplication, division
 - FSQRT- square root
 - FUCOM- compare
 - FCHS - change sign
 - FABS - absolute value
 - FSIN, FCOS- sine, cosine
 - FTAN, FATAN- tangent, arcs tangent
- And more peripherals

CONFIGURATION

The following parameters of the DP8051XP core can be easily adjusted to requirements of dedicated application and technology. Configuration of the core can be prepared by effortlessly changing appropriate constants in package file. There is no need to change any parts of the code.

- Internal Program Memory type
 - synchronous
 - asynchronous
- Internal Program ROM Memory size
 - 0 - 64kB
- Internal Program RAM Memory size
 - 0 - 64kB
- Internal Program Memory fixed size
 - true
 - false
- Second Data Pointer (DPTR1)
 - used
 - unused
- DPTR0 decrement
 - used
 - unused
- DPTR1 decrement
 - used
 - unused
- Data Pointers auto-switch
 - used
 - unused
- Interrupts
 - subroutines
 - location
- Timing access protection
 - used
 - unused
- Power Management Mode
 - used
 - unused
- Stop mode
 - used
 - unused
- DoCD™ debug unit
 - used
 - unused

Besides mentioned above parameters all available peripherals and external interrupts can be excluded from the core by changing appropriate constants in package file.

- ◆ Source code:
 - VHDL Source Code or/and
 - VERILOG Source Code or/and
 - FPGA netlist
- ◆ VHDL & VERILOG test bench environment
 - Active-HDL automatic simulation macros
 - ModelSim automatic simulation macros
 - Tests with reference responses
- ◆ Technical documentation
 - Installation notes
 - HDL core specification
 - Datasheet
- ◆ Synthesis scripts
- ◆ Example application
- ◆ Technical support
 - IP Core implementation support
 - 3 months maintenance
 - Delivery the IP Core updates, minor and major versions changes
 - Delivery the documentation updates
 - Phone & email support

DELIVERABLES

LICENSING

Comprehensible and clearly defined licensing methods without royalty per chip fees make using of IP Core easy and simply.

Single Site license option is dedicated for small and middle sized companies making its business in one place.

Multi Sites license option is dedicated for corporate customers making its business in several places. Licensed product can be used in selected branches of corporate.

In all cases number of IP Core instantiations within a project, and number of manufactured chips are unlimited. The license is royalty per chip free. There is no time of use restrictions.

There are two formats of delivered IP Core

- VHDL, Verilog RTL synthesizable source code called HDL Source
- FPGA EDIF/NGO/NGD/QXP/VQM called Net-list

DESIGN FEATURES

◆ PROGRAM MEMORY:

The DP8051XP soft core is dedicated for operation with Internal and External Program Memory. Internal Program Memory can be implemented as:

- ROM located in address range between $0x0000 \div (ROM_{size}-1)$
- RAM located in address range between $(RAM_{size}-1) \div 0xFFFF$

External Program Memory can be implemented as ROM or RAM located in address range between $ROM_{size} \div RAM_{size}$.

◆ INTERNAL DATA MEMORY:

The DP8051XP can address Internal Data Memory of up to 256 bytes The Internal Data Memory can be implemented as Single-Port synchronous RAM.

◆ EXTERNAL DATA MEMORY:

The DP8051XP soft core can address up to 16 MB of External Data Memory. Extra DPX (*Data Pointer eXtended*) register is used for segments swapping.

◆ USER SPECIAL FUNCTION REGISTERS:

Up to 60 External (user) Special Function Registers (ESFRs) may be added to the DP8051XP design. ESFRs are memory mapped into Direct Memory between addresses $0x80$ and $0xFF$ in the same manner as core SFRs and may occupy any address that is not occupied by a core SFR.

◆ WAIT STATES SUPPORT:

The DP8051XP soft core is dedicated for operation with wide range of Program and Data memories. Slow Program and External Data memory may assert a memory Wait signal to hold up CPU activity.



SYMBOL

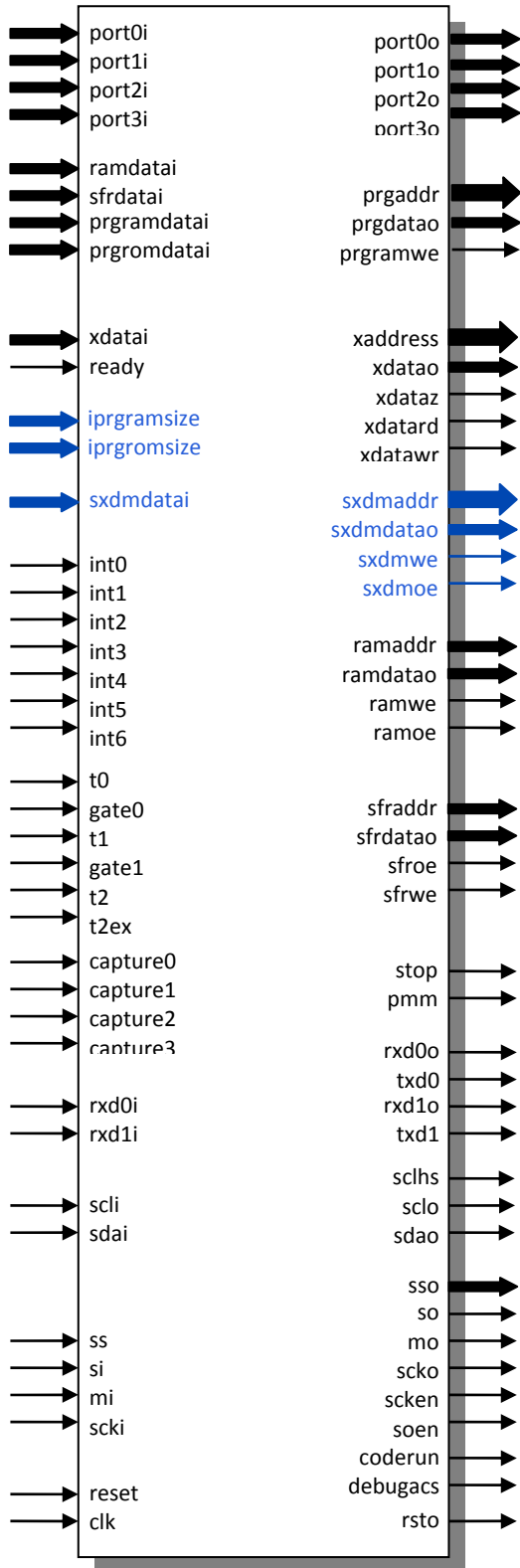

BLOCK DIAGRAM

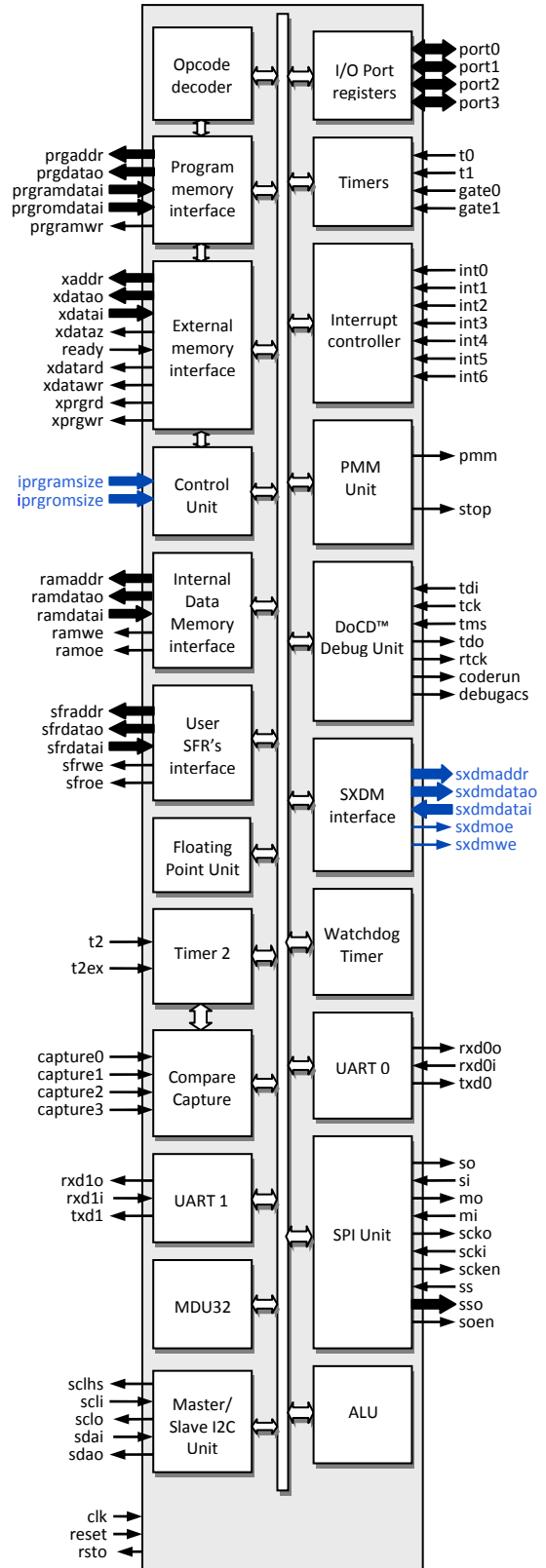

PINS DESCRIPTION

PIN	TYPE	DESCRIPTION
clk	input	Global clock
reset	input	Global reset
port0i	input	Port 0 input
port1i	input	Port 1 input
port2i	input	Port 2 input
port3i	input	Port 3 input
lprgramsize	input	Size of on-chip RAM CODE
lprgromsize	input	Size of on-chip ROM CODE
prgramdata	input	Data bus from int. RAM prog. memory
prgromdata	input	Data bus from int. ROM prog. memory
sxdmdatai	input	Data bus from sync external data memory (SXDM)
xdatai	input	Data bus from external memories
ready	input	External memory data ready
ramdatai	input	Data bus from internal data memory
sfrdatai	input	Data bus from user SFR's
int0	input	External interrupt 0
int1	input	External interrupt 1
int2	input	External interrupt 2
int3	input	External interrupt 3
int4	input	External interrupt 4
int5	input	External interrupt 5
int6	input	External interrupt 6
t0	input	Timer 0 input
t1	input	Timer 1 input
t2	input	Timer 2 input
gate0	input	Timer 0 gate input
gate1	input	Timer 1 gate input
t2ex	input	Timer 2 gate input
capture0	input	Timer 2 capture 0 line
capture1	input	Timer 2 capture 1 line
capture2	input	Timer 2 capture 2 line
capture3	input	Timer 2 capture 3 line
rxdi0	input	Serial receiver input 0
rxdi1	input	Serial receiver input 1
scli	input	Master/Slave I2C clock line input
sdai	input	Master/Slave I2C data input
ss	input	SPI slave select
si	input	SPI slave input
mi	input	SPI master input
scki	input	SPI clock input
tdi	input	DoCD™ TAP data input
tck	input	DoCD™ TAP clock input

PIN	TYPE	DESCRIPTION
tms	input	DoCD™ TAP mode select input
rsto	output	Reset output
port0o	output	Port 0 output
port1o	output	Port 1 output
port2o	output	Port 2 output
port3o	output	Port 3 output
prgaddr	output	Internal program memory address bus
prgdatao	output	Data bus for internal program memory
prgramwr	output	Internal program memory write
sxdmaddr	output	Sync XDATA memory address bus (SXDM)
sxdmdatao	output	Data bus for Sync XDATA memory (SXDM)
sxdmoe	output	Sync XDATA memory read (SXDM)
sxdmwe	output	Sync XDATA memory write (SXDM)
xaddr	output	Address bus for external memories
xdatao	output	Data bus for external memories
xdataz	output	Turn xdata bus into 'Z' state
xprgrd	output	External program memory read
xprgwr	output	External program memory write
xdatard	output	External data memory read
xdatawr	output	External data memory write
ramaddr	output	Internal Data Memory address bus
ramdatao	output	Data bus for internal data memory
ramoe	output	Internal data memory output enable
ramwe	output	Internal data memory write enable
sfraddr	output	Address bus for user SFR's
sfrdatao	output	Data bus for user SFR's
sfroe	output	User SFR's read enable
sfrwe	output	User SFR's write enable
tdo	output	DoCD™ TAP data output
rtck	output	DoCD™ return clock line
debugacs	output	DoCD™ accessing data
coderrun	output	CPU is executing an instruction
pmm	output	Power management mode indicator
stop	output	Stop mode indicator
rxdo0	output	Serial receiver output 0
rxdo1	output	Serial receiver output 1
txdo0	output	Serial transmitter output 0
txdo1	output	Serial transmitter output 1
sclo	output	Master/Slave I2C clock output
sclhs	output	High speed Master I2C clock line
sdao	output	Master/Slave I2C data output
sso	output	SPI slave select lines
so	output	SPI slave output
mo	output	SPI master output

PIN	TYPE	DESCRIPTION
scko	output	SPI clock output
scken	output	SPI clock line tri-state buffer control
soen	output	SPI slave output enable

UNITS SUMMARY

ALU – Arithmetic Logic Unit performs the arithmetic and logic operations during execution of an instruction. It contains accumulator (ACC), Program Status Word (PSW), (B) registers and related logic such as arithmetic unit, logic unit, multiplier and divider.

Opcode Decoder – Performs an instruction opcode decoding and the control functions for all other blocks.

Control Unit – Performs the core synchronization and data flow control. This module is directly connected to Opcode Decoder and manages execution of all microcontroller tasks.

Program Memory Interface – Contains Program Counter (PC) and related logic. It performs the instructions code fetching. Program Memory can be also written. This feature allows usage of a small boot loader loading new program into RAM, EPROM or FLASH EEPROM storage via UART, SPI, I2C or DoCD™ module.

External Memory Interface - Contains memory access related registers such as Data Page High (DPH), Data Page Low (DPL) and Data Pointer eXtended (DPX) registers. It performs the external Program and Data Memory addressing and data transfers. Program fetch cycle length can be programmed by user. This feature is called Program Memory Wait States, and allows core to work with different speed program memories.

Synchronous eXternal Data Memory (SXDM) Interface – contains XDATA memory access related logic allowing fast access to synchronous memory devices. It performs the external Data Memory addressing and data transfers. This memory can be used to store large variables frequently accessed by CPU, improving overall performance of application.

Internal Data Memory Interface – Internal Data Memory interface controls access into the internal

256 bytes memory. It contains 8-bit Stack Pointer (SP) register and related logic.

User SFRs Interface – Special Function Registers interface controls access to the special registers. It contains standard and used defined registers and related logic. User defined external devices can be quickly accessed (read, written, modified) using all direct addressing mode instructions.

Interrupt Controller – Interrupt control module is responsible for the interrupt manage system for the external and internal interrupt sources. It contains interrupt related registers such as Interrupt Enable (IE), Interrupt Priority (IP), Extended Interrupt Enable (EIE), Extended Interrupt priority (EIP) and (TCON) registers.

I/O Ports – Block contains 8051's general purpose I/O ports. Each of port's pin can be read/write as a single bit or as an 8-bit bus called P0, P1, P2, and P3.

Power Management Unit – Block contains advanced power saving mechanisms with switchback feature, allowing external clock control logic to stop clocking (Stop mode) or run core in lower clock frequency (Power Management Mode) to significantly reduce power consumption. Switchback feature allows UARTs, and interrupts to be processed in full speed mode if enabled. It is very desired when microcontroller is planned to use in portable and power critical applications.

DoCD™ Debug Unit – it's a real-time hardware debugger provides debugging capability of a whole SoC system. In contrast to other on-chip debuggers DoCD™ provides non-intrusive debugging of running application. It can halt, run, step into or skip an instruction, read/write any contents of microcontroller including all registers, internal, external, program memories, all SFRs including user defined peripherals. Hardware breakpoints can be set and controlled on program memory, internal and external data memories, as well as on SFRs. Hardware breakpoint is executed if any write/read occurred at particular address with certain data pattern or without pattern. Two additional pins CODERUN, DEBUGACS indicate the state of the debugger and CPU. CODERUN is active when CPU is executing an instruction. DEBUGACS pin is active when any access is performed by DoCD™ debug-

ger. The DoCD™ system includes **JTAG interface** and complete set of tools to communicate and work with core in real time debugging. It is built as scalable unit and some features can be turned off to save silicon and reduce power consumption. A special care on power consumption has been taken, and when debugger is not used it is automatically switched in power save mode. Finally whole debugger is turned off when debug option is no longer used.

Floating Point Unit – Block contains floating point arithmetic IEEE-754 compliant instructions (*C float, int, long int* types supported). It is used to execute single precision floating point operations such as: addition, subtraction, multiplication, division, square root, comparison absolute value of number and change of sign. Basing on specialized CORDIC algorithm a full set of trigonometric operations are also allowed: sine, cosine, tangent, arctangent. It also has built-in integer to floating point and vice versa conversion instructions. FPU supports single precision real numbers, 16-bit and 32-bit signed integers. This unit has included standard software interface allows easy usage and interfacing with user C/ASM written programs.

MDU32 Multiply Divide Unit – It's a fixed point fast 16-bit and 32-bit multiplication and division unit. It supports unsigned and 2's complement signed integer operands. The MDU32 is controlled by dedicated direct memory access module (called DMA). All arguments and result registers are automatically read and written back by internal DMA. This unit has included standard software interface allows easy usage and interfacing with user C/ASM written programs. This module is replacement of older MDU.

Timers – System timers' module. Contains two 16 bits configurable timers: Timer 0 (TH0, TL0), Timer 1 (TH1, TL1) and Timers Mode (TMOD) registers. In the timer mode, timer registers are incremented every 12 CLK periods when appropriate timer is enabled. In the counter mode the timer registers are incremented every falling transition on their corresponding input pins (T0, T1), if gates are opened (GATE0, GATE1). T0, T1 input pins are sampled every CLK period. It can be used as clock source for UARTs.

Timer 2 – Second system timer module contains one 16-bit configurable timer: Timer 2 (TH2, TL2), capture registers (RLDH, RLDL) and Timer 2 Mode (T2MOD) register. It can work as a 16-bit timer / counter, 16-bit auto-reload timer / counter. It also supports compare capture unit if it's presented in system. It can be used as clock source for UART0.

Compare Capture Unit – The compare / capture / reload unit is one of the most powerful peripheral units of the core. It can be used for all kinds of digital signal generation and event capturing such as pulse generation, pulse width modulation, measurements etc.

Watchdog Timer – The watchdog timer is a 27-bit counter which is incremented every system clock periods (CLK pin). It performs system protection against software upsets.

UART0 – Universal Asynchronous Receiver & Transmitter module is full duplex, meaning it can transmit and receive concurrently. Includes Serial Configuration register (SCON), serial receiver and transmitter buffer (SBUF) registers. Its receiver is double-buffered, meaning it can commence reception of a second byte before a previously received byte has been read from the receive register. Writing to SBUF0 loads the transmit register, and reading SBUF0 reads a physically separate receive register. It works in 3 asynchronous and 1 synchronous modes. UART0 can be synchronized by Timer 1 or Timer 2.

UART1 – Universal Asynchronous Receiver & Transmitter module is full duplex, meaning it can transmit and receive concurrently. Includes Serial Configuration register (SCON1), serial receiver and transmitter buffer (SBUF1) registers. Its receiver is double-buffered, meaning it can commence reception of a second byte before a previously received byte has been read from the receive register. Writing to SBUF1 loads the transmit register, and reading SBUF1 reads a physically separate receive register. It works in 3 asynchronous and 1 synchronous modes. UART1 is synchronized by Timer 1.

Master I2C Unit – I2C bus controller is a Master module. The core incorporates all features required by I2C specification. It supports both 7-bit and 10-bit addressing modes on the I2C bus. It works as a master transmitter and receiver. It can



be programmed to operate with arbitration and clock synchronization to allow it operates in multi-master systems. Built-in timer allows operation from a wide range of the input frequencies. The timer allows achieving any non-standard clock frequency. The I2C controller supports all transmission modes: Standard, Fast and High Speed up to 3400 kbps.

Slave I2C Unit – I2C bus controller is a Slave module. The core incorporates all features required by I2C specification. It works as a slave transmitter/receiver depending on working mode determined by a master device. The I2C controller supports all transmission modes: Standard, Fast and High Speed up to 3400 kbs.

SPI Unit – it's a fully configurable master/slave Serial Peripheral Interface, which allows user to configure polarity and phase of serial clock signal SCK. It allows the microcontroller to communicate with serial peripheral devices. It is also capable of interprocessor communications in a multi-master system. A serial clock line (SCK) synchronizes shifting and sampling of the information on the two independent serial data lines. SPI data are simultaneously transmitted and received. SPI system is flexible enough to interface directly with numerous standard product peripherals from several manufacturers. Data rates as high as CLK/4. Clock control logic allows a selection of clock polarity and a choice of two fundamentally different clocking protocols to accommodate most available synchronous serial peripheral devices. When the SPI is configured as a master, software selects one of four different bit rates for the serial clock. SPI automatically drives slave select outputs SSO[7:0], and address SPI slave device to exchange serially shifted data. Error-detection logic is included to support interprocessor communications. A write-collision detector indicates when an attempt is made to write data to the serial shift register while a transfer is in progress. A multiple-master mode-fault detector automatically disables SPI output drivers if more than one SPI devices simultaneously attempts to become bus master.

PROGRAM CODE SPACE IMPLEMENTATION

The figure below shows an example Program Memory space implementation in systems with DP8051XP Microcontroller core. The On-chip Program Memory located in address space between 0kB and 1kB is typically used for BOOT code with system initialization functions. This part of the code is typically implemented as ROM. The On-chip Program Memory located in address space between 60kB and 64kB is typically used for timing critical part of the code e.g. interrupt subroutines, arithmetic functions etc. This part of the code is typically implemented as RAM and can be loaded by the BOOT code during initialization phase from Off-chip memory or through RS232 interface from external device. From the two mentioned above spaces program code is executed without wait-states and can achieve a top performance up to 200 million instructions per second (many instructions executed in one clock cycle). The Off-chip Program Memory located in address space between 1kB and 60kB is typically used for main code and constants. This part of the code is usually implemented as ROM, SRAM or FLASH device. Because of relatively long access time the program code executed from mentioned above devices must be fetched with additional Wait-States. Number of required Wait-States depends on memory access time and DP8051XP clock frequency. In most cases, the proper number of Wait-States cycles is in range 2 to 5. The READY pin can be also dynamically modulated e.g. by SDRAM controller.

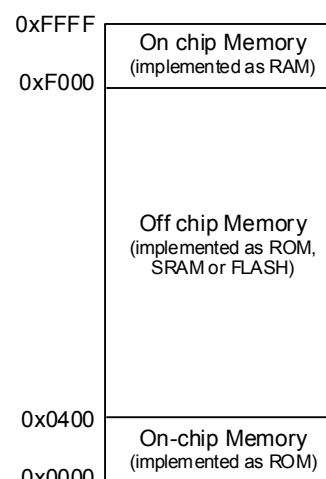

The figure below shows typical Program Memories connections in system with DP8051XP Microcontroller core.

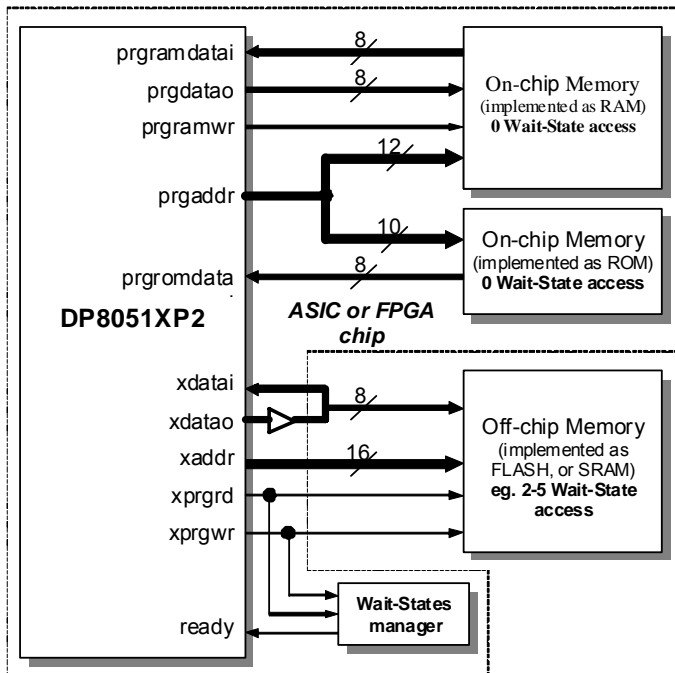

The described above implementation should be treated as an example. All Program Memory spaces are fully configurable. For timing-critical applications whole program code can be implemented as on-chip ROM and (or) RAM and executed without Wait-States, but for some other applications whole program code can be implemented as off-chip ROM or FLASH and executed with required number Wait-State cycles.

The main features of each DP8051 family member have been summarized in table below. It gives a briefly member characterization helping user to select the most suitable IP Core for its application. User can specify its own peripheral set (including listed below and the others) and requests the core modifications.

Design	Architecture speed grade	Program Memory space			Stack space size	Internal Data Memory space	External Data Memory space	External Data / Program Memory Wait States	Power Management Unit	Interface for additional SFRs	Interrupt sources	Interrupt levels	Data Pointers	Timer/Counters	UART	I/O Ports	Compare/Capture	Watchdog	Master I ² C Bus Controller	Slave I ² C Bus Controller	SPI	Fixed Point Coprocessor	Floating Point Coprocessor
		on-chip RAM	on-chip ROM	off-chip																			
DP8051CPU	15.6	64k	64k	64k	256	256	16M	✓	✓	✓	2	2	1	-	-	-	-	-	-	-	-	-	-
DP8051	15.6	64k	64k	64k	256	256	16M	✓	✓	✓	5	2	1	2	1	4	-	-	-	-	-	-	-
DP8051XP	15.6	64k	64k	64k	256	256	16M	✓	✓	✓	15	2	2	3	2	4	✓	✓	✓	✓	✓	✓	✓

DP8051 family of Pipelined High Performance Microcontroller Cores

The main features of each DP80390 family member have been summarized in table below. It gives a briefly member characterization helping user to select the most suitable IP Core for its application. User can specify its own peripheral set (including listed below and the others) and requests the core modifications.

Design	Architecture speed grade	Program Memory space			Stack space size	Internal Data Memory space	External Data Memory space	External Data / Program Memory Wait States	Power Management Unit	Interface for additional SFRs	Interrupt sources	Interrupt levels	Data Pointers	Timer/Counters	UART	I/O Ports	Compare/Capture	Watchdog	Master I ² C Bus Controller	Slave I ² C Bus Controller	SPI	Fixed Point Coprocessor	Floating Point Coprocessor
		on-chip RAM	on-chip ROM	off-chip																			
DP80390CPU	15.6	64k	64k	8M	256	256	16M	✓	✓	✓	2	2	1	-	-	-	-	-	-	-	-	-	-
DP80390	15.6	64k	64k	8M	256	256	16M	✓	✓	✓	5	2	1	2	1	4	-	-	-	-	-	-	-
DP80390XP	15.6	64k	64k	8M	256	256	16M	✓	✓	✓	15	2	2	3	2	4	✓	✓	✓	✓	✓	✓	✓

DP80390 family of Pipelined High Performance Microcontroller Cores

CONTACTS

For any modification or special request contact to DCD.

Headquarters:

Wroclawska 94

41-902 Bytom, POLAND

e-mail: info@dcd.pl

tel. : +48 32 282 82 66

fax : +48 32 282 74 37

Distributors:

Please check <http://www.dcd.pl/apartn.php>